



Reflex LR – Level Controller (Ultrasonic Level Measurement)

Installation & Operation Instruction Manual



**Hycontrol Limited, Larchwood House, Orchard Street,
Redditch, Worcestershire, UK. B98 7DP
Tel: + 00 44 (0)1527 406800 Fax: +00 44(0)1527 406810
Email: sales@hycontrol.com Web: www.hycontrol.com**

INDEX

	PAGE
1. GENERAL DESCRIPTION	3
1.1. Reflex LR & Transducers	4
2. INSTALLATION GUIDE	5
2.1. Controller Installation	5
2.2. Controller Installation Dimensions	5
2.3. Transducer Installation	6
2.4. Transducer Installation Dimensions	7
2.5. Installation Wiring	8
2.5.1. Wiring Diagram – Controller to Transducer	8
2.5.2. Wiring Diagram – Reflex 2DC	8
2.5.3. Wiring Diagram – Reflex 234	9
2.5.3.1. Reflex 234 - Terminal Connections for AC supply	9
a. Modulating from User's External DC Supply (RL to Pos)	9
b. Modulating from User's External DC Supply (RL to Neg)	9
c. 4 Wire DC – Driving from Internal Isolated Supply (Is)	9
2.5.3.2. Reflex 234 – Terminal Connections for DC Supply	10
a. 4 Wire DC – Driving from Internal Isolated Supply (Is)	10
b. 3 Wire DC – Modulating from Common User Supply (RL to +DC)	10
c. 3 Wire DC – Modulating from Common User Supply (RL to GND)	10
2.6. Hycontrol Link Wiring for Remote diagnostics via GSM	11
3. PROGRAMMING	12
3.1. Entering Data	12
3.2. Access to Main Menu	12
3.3. Entering Basic Data – QUICKSET	13
3.3.1. Flow – Programming	14
3.3.2. Volume	15
3.4. Entering Output Adjustments	15
3.5. Tx Set-up for Gain and Threshold	16
3.6. Diagnostic Display	17
4. GENERAL SPECIFICATION	18
5. PART NUMBER SELECTION	19 - 20
6. LABELLING INFORMATION	21
7. MODBUS REGISTER LIST	22 - 25
8. ASSEMBLY OF FLANGE AND CONES	26
APPENDIX A. CROSS TALK PREVENTION	27 - 28
APPENDIX B. DIFFERENTIAL LEVEL MEASUREMENT	29 - 32
APPENDIX C. APPLICATIONS TYPES	33 - 34

USER MANUAL

REFLEX LR LONG RANGE LEVEL CONTROLLER

1. GENERAL DESCRIPTION

The Reflex LR Controller is capable of non-contact level measurement over distances of up to 60 metres, depending on the application. It is an intelligent system approach to measurement of solids and liquids with maximum performance combined with a display and keypad.

Reflex LR is available with four different transducers for ranges of 10, 20, 40 and 60 metre operation. Each configuration is available as a 2-wire, DC powered 4-20mA loop (Reflex LR 2DC) or 2, 3 and 4 wire DC and AC powered (Reflex LR 234) with a combination of Modbus, 5 relays, 4-20mA and PC comms outputs.

The Controller should be mounted where the display is readily visible and acceptable for easy programming; the transducer must be mounted directly above the surface of the material to be monitored.

Ultrasonic pulses are transmitted to the surface of the material to be monitored and reflected back to the transducer. The time period between transmission and reception of the pulses is directly proportional to the distance between the transducer and the material.

Since the speed of sound through air is affected by temperature, a temperature sensor is integrated into the face of the transducer to improve accuracy.

Reflex LR is suitable for measuring the following on solids and liquids:

- a) Ullage space or distance to material
- b) Material level
- c) Volume measurement
- d) Material percentage
- e) Flow of liquids in open channels

WARNING

Do not open the Controller terminal cover or remove any connection whilst the power is ON.

**REFER TO 'ATEX Safety & Operating Instructions Manual'
IF INSTALLING IN A HAZARDOUS AREA**

1.1 Reflex LR

Reflex LR is an easy to use level controller available with four (4) different high power, low frequency transducers, types RVT10, 20, 40 and 60, capable of reliably tracking the level of solids and liquids under difficult conditions, programmed via a 4 button keypad and an integral menu driven display.



Reflex LR 2DC only has a 4-20mA output whereas Reflex LR 234 has 5 individually programmed relays and can provide 4-20mA, PC Comms, Modbus, Profibus or Hart communications; up to 32 instruments can be networked together.

If specified, the transducers are available approved for ATEX EEx ia zone 0 gases & zone 20 dusts, ATEX dust protection only zone 20, or ATEX EEx m protection zone 1 gases & zone 21 dusts. The controller is available approved to ATEX EEx ia zone 0 gases & zone 20 dusts (Reflex LR 2DC 24v 4-20ma loop only).

Remote programming of the product is available via Hycontrol's Vision System II software and all the instruments can be connected via the Hycontrol Link to a Service Engineer in the Redditch office to analyse and overcome any problems which may be experienced in the field, without incurring any expensive call-out charges.



Focalisers are used with the longer range 20-60 metre transducers in order to improve signal strength and ensure continuous tracking of material level under dirty, dusty conditions.

2. INSTALLATION GUIDE

2.1 Controller Installation

Select a suitable mounting position that is not in direct sunlight; if necessary use a sunshade. Observe the minimum and maximum temperature limits (-20°C / -4°F to 60°C / 140°F)*. Ensure that the mounting surface is not subject to vibration and is not in close proximity to high voltage power cables, contactors or drive controls. If the controller is mounted outside it should be protected from direct sunlight or severe weather conditions.

Conduit entries should be knocked out by tapping the grooved circumference, care should be taken not to damage the internal PCB assembly.

2.2 Controller Installation Dimensions

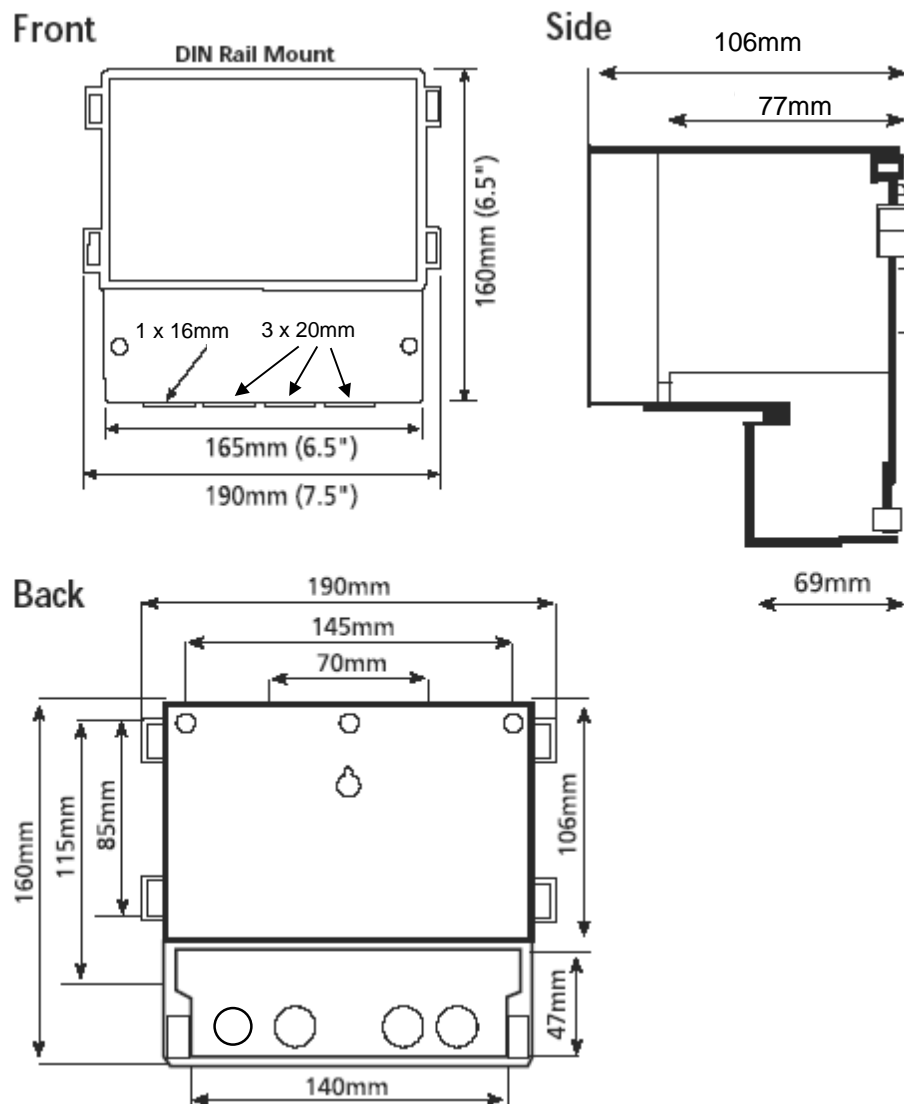

*For ATEX temperature classifications see ATEX Safety & Operating Instructions Manual.

2.3 Transducer Installation

The RVT Transducers are designed to be screwed directly into a flange on a tank. For long range and dusty applications, the use of a focaliser on the underside of the flange improves the concentration of the signal and ensures that spurious signals are eliminated.

Ensure that the mounting surface is not subject to vibration and is not in close proximity to high voltage power cables, contactors or drive controls. If the transducer is mounted outside it should be protected from direct sunlight or severe weather conditions. Observe the minimum and maximum temperature limits refer to part number selection on Page 20.

When using a focaliser cone, ensure that it protrudes at least 50mm into the vessel.

The transducer must be installed to ensure a clear line of sight from the transducer face to the product being monitored. Refer to diagram, on Page 7.

Avoid mounting near fill point, ladders, baffles, agitators etc.

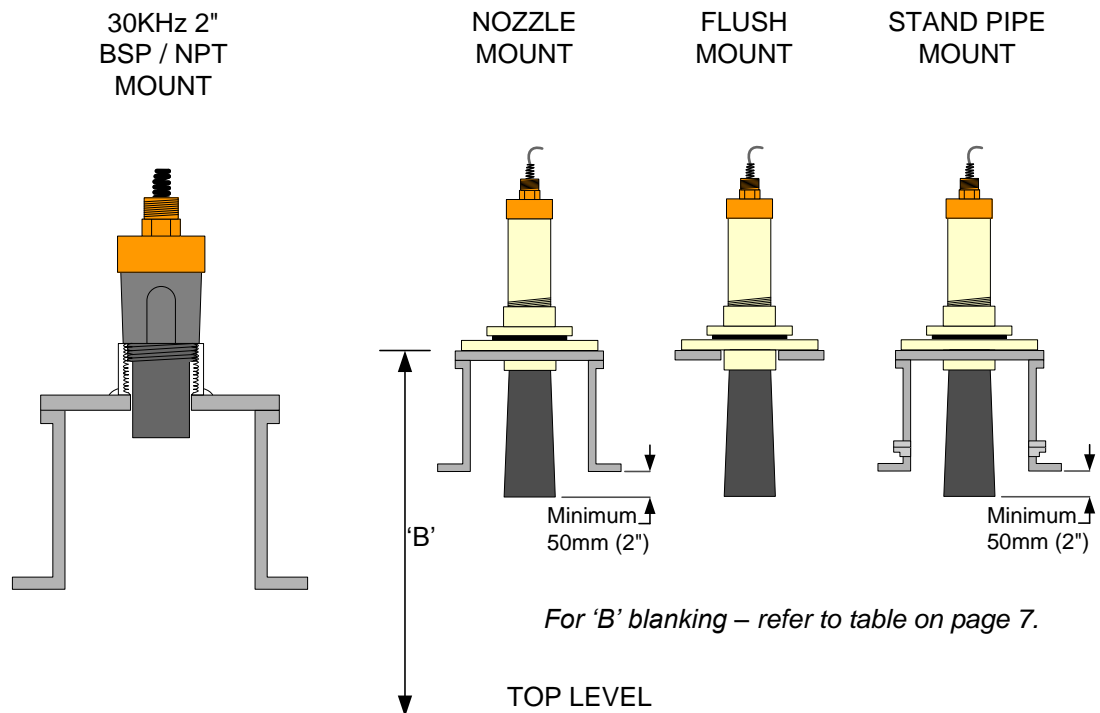

*For ATEX temperature classifications see ATEX Safety & Operating Instructions Manual.

Transducer Mounting

SOLID (Granular)

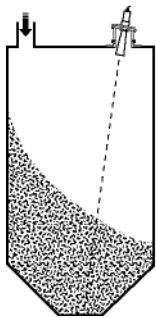

Aim transducer at point of outfeed.

LIQUID

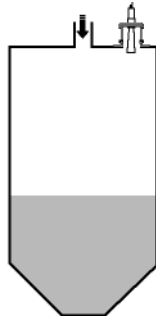

Transducer should be as perpendicular to product as practicable.

DUAL OUTFEED



Use two transducers and wire and program as shown in Appendix A to avoid cross-talk.

POWDER

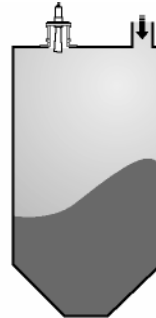

Mount away from infeed

2.4 Transducer Installation Dimensions

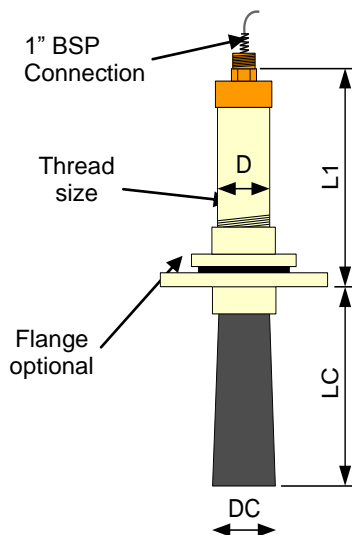

Range Metres	L1	LC Optional	D	DC Optional	Thread Size	Flange Optional
10	200	-	50	-	2"	-
20	280	275	75	98	3"	4"
40	436	413	89	236	3.5"	10"
60	719	460	89	236	-	10"

Flange Options: ANSI, DIN or JIS

Dimensions for 10, 20, 40 & 60 metre range

Ensure the distance between the transducer face and the highest expected product level in the tank is always greater than the Blanking Distance value. See table below.

TRANSDUCER	BLANKING DISTANCE	
	Minimum	Nominal
RVT10	0.35m (1.2ft)	0.5m (1.6ft)
RVT20	0.50m (1.6ft)	0.8m (2.6 ft)
RVT40	1.0m (3.3ft)	1.3m (4.2 ft)
RVT60	1.2m (4 ft)	1.5m (5 ft)

2.5 Installation Wiring

2.5.1 Wiring Diagram - Controller to Transducer

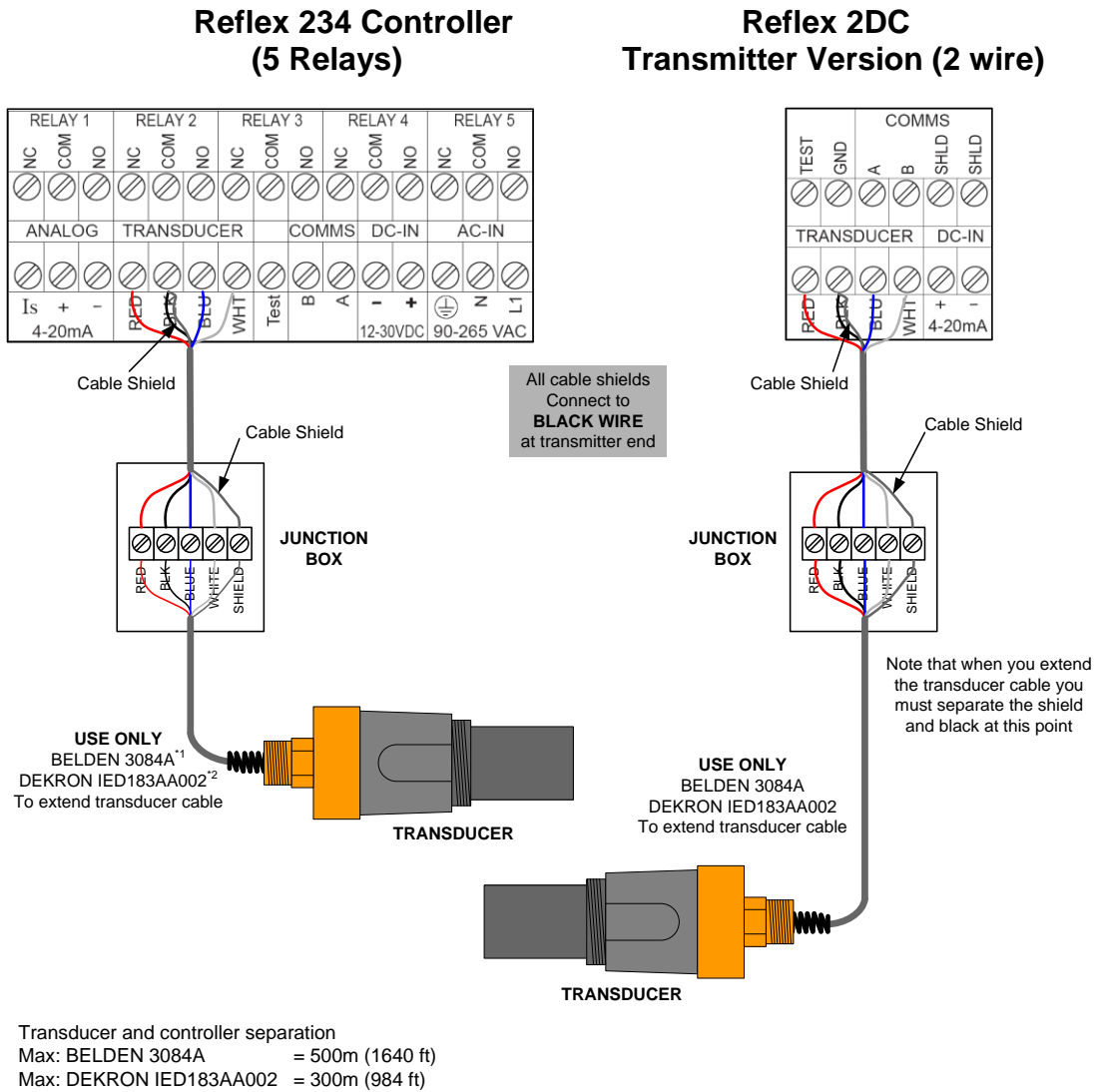

2.5.2 Wiring Diagram - Reflex 2DC

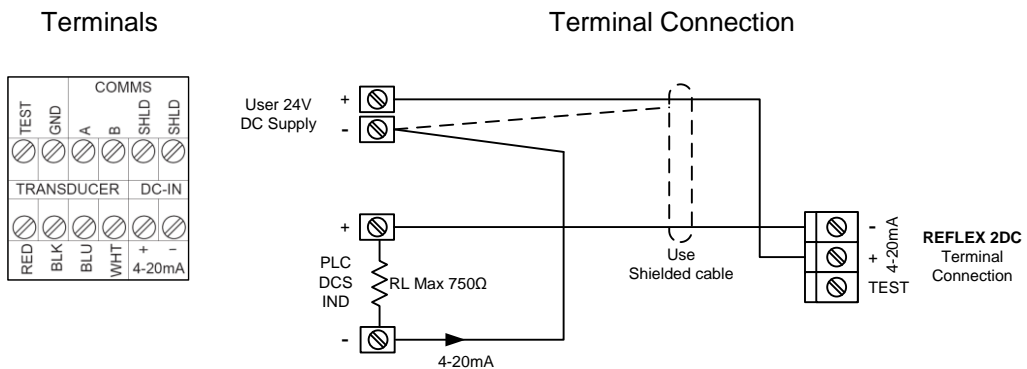

2.5.3 Wiring Diagram – Reflex 234

2.5.3.1 Reflex 234 – Terminal Connections for AC Supply

a) Modulating from User's External DC Supply (RL to Pos.)

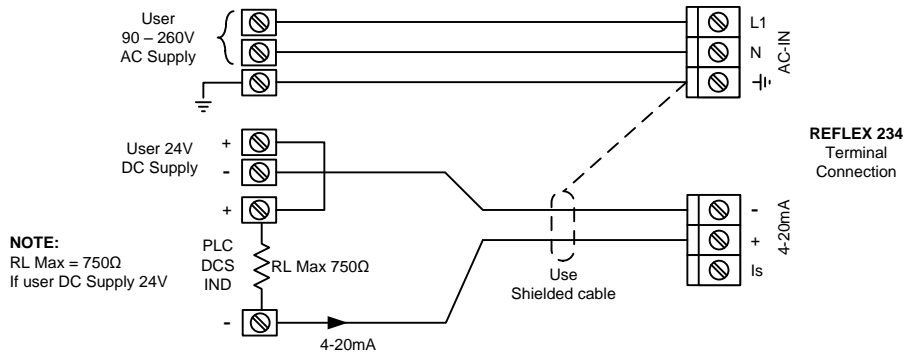

b) Modulating from User's External DC Supply (RL to Neg.)

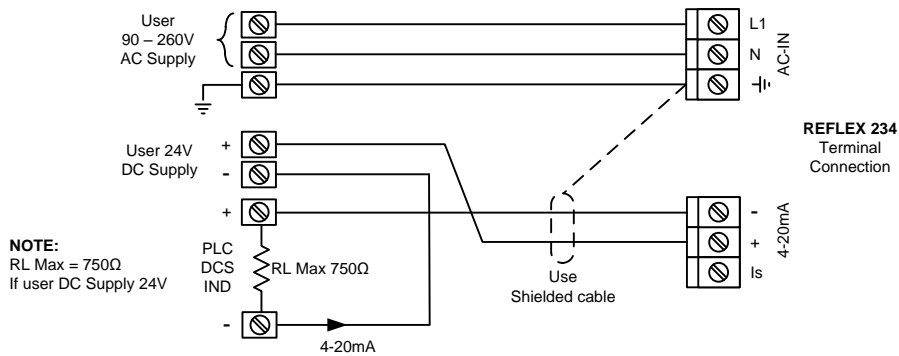

c) 4 Wire DC – Driving from Internal Isolated Supply (Is)

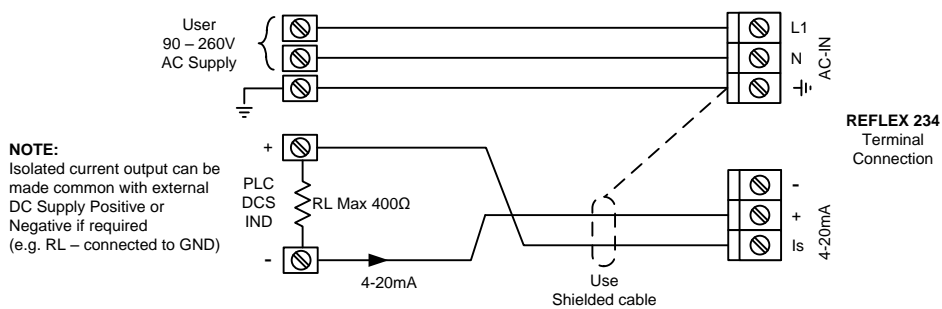

2.5.3.2 Reflex 234 – Terminal Connection for DC Supply

a) 4 Wire DC – Driving from Internal Isolated Supply (Is)

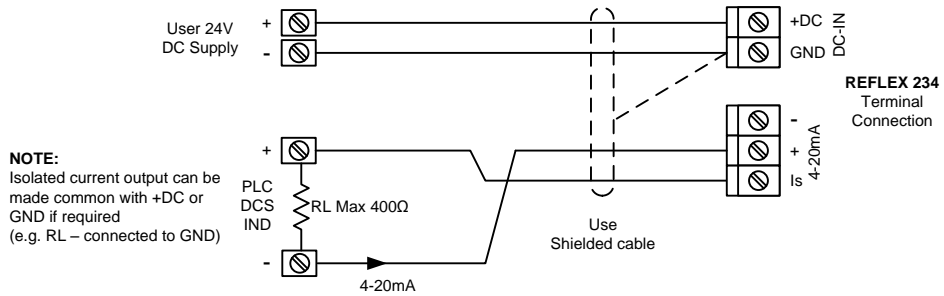

b) 3 Wire DC – Modulating from Common User Supply (RL to +DC)

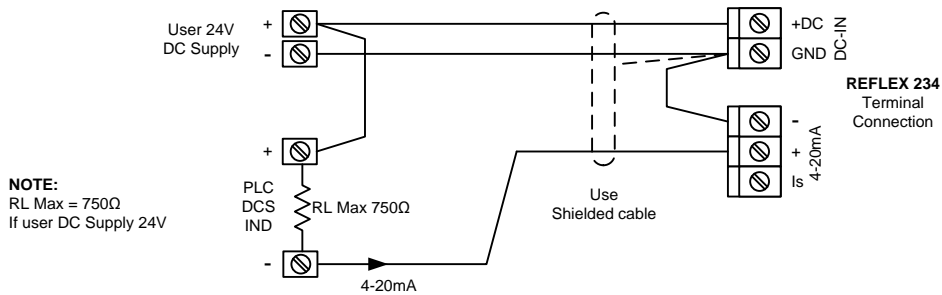

c) 3 Wire DC – Modulating from Common User Supply (RL to GND)

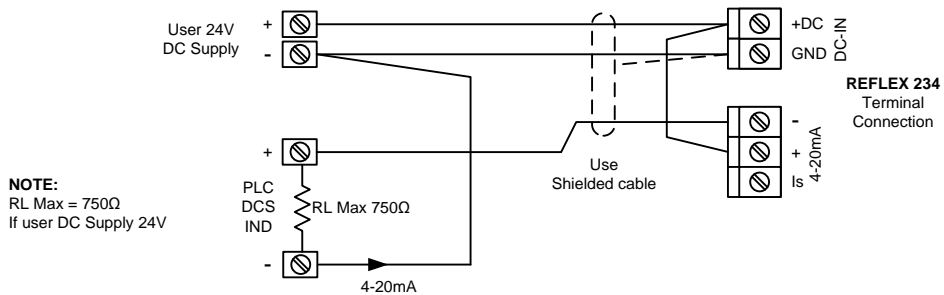

2.6 Hycontrol Link GSM Connection

The Hycontrol Link is a separately powered GSM module which enables Hycontrol Service Engineers to interrogate and program any Reflex LR Controller.

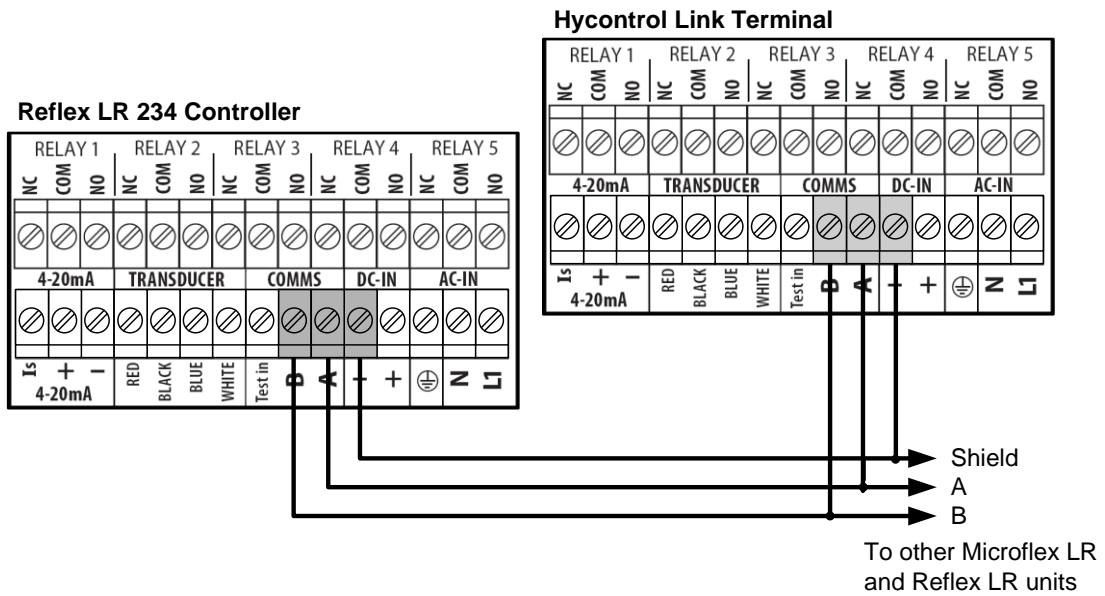

The following diagram shows how to wire it to the Reflex LR.



3. PROGRAMMING – Integral via 4 buttons & display

3.1 Entering Data

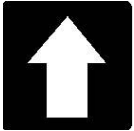
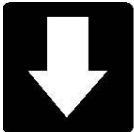
All software adjustments are achieved via the four PUSH BUTTONS on the front panel of the Transmitter.

	<p>(A) Press for 3 secs – this interrupts normal operations to allow access to customized options and enables headings and functions to be edited. IN SET-UP</p> <p>(B) Momentary press – saves selected value. Press and hold – scrolls through set-up menus and parameters.</p>
	<p>(A) Increases displayed value.</p> <p>(B) Scrolls up through software set-up options.</p>
	<p>(A) Decreases displayed value.</p> <p>(B) Scrolls down through software set-up options.</p>
	<p>(A) One press takes the user back one step. Press twice when all selections are finished.</p> <p>(B) Stores the current set-up in memory and checks the validity of the software selections, then returns the instrument to normal operating condition.</p>

Use these 4 buttons along with the following ‘software tree’ to customize the instrument for your application.

3.2 To access main menu

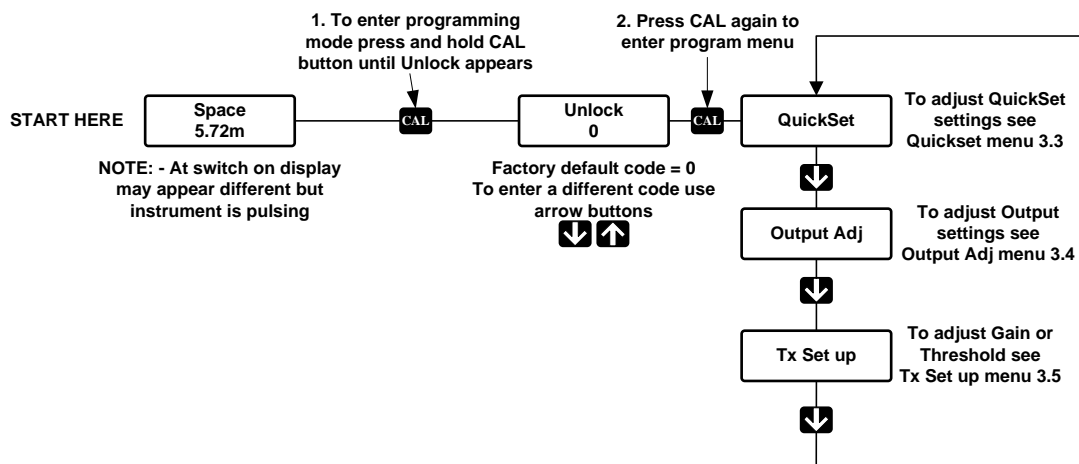

3.3 Entering Basic Data – QUICKSET

Go to QUICKSET and enter the values for the specific application.

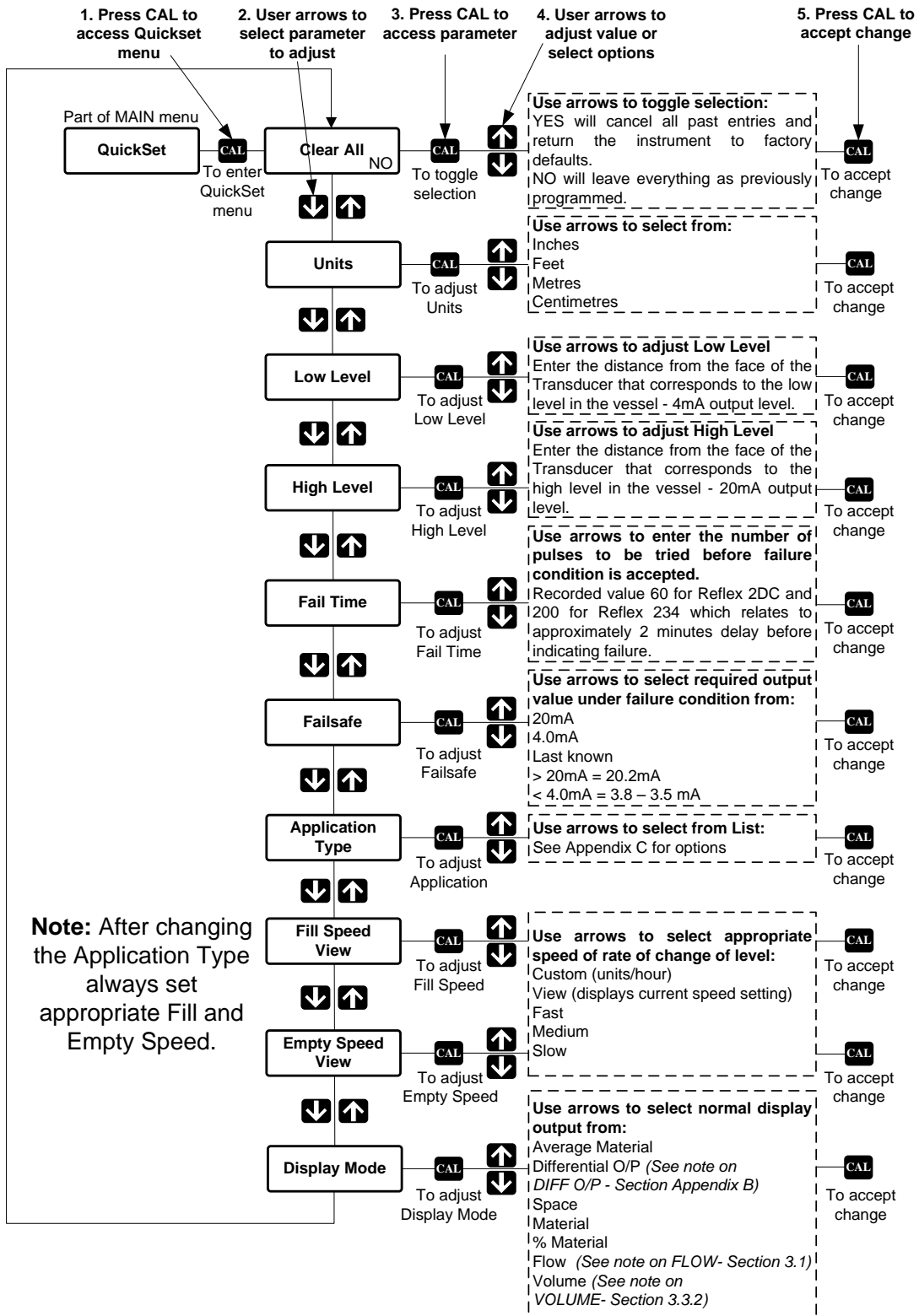

Note: After changing the Application Type always set appropriate Fill and Empty Speed.

***Press RUN twice to exit program mode and revert to normal operation**

3.3.1 Flow - Programming

In the QUICKSET menu, Section 3.3 select Flow as the Display Mode to allow open channel flow using $q = kh^n$. This enables 4 additional parameters allowing the instrument to be programmed for flow.

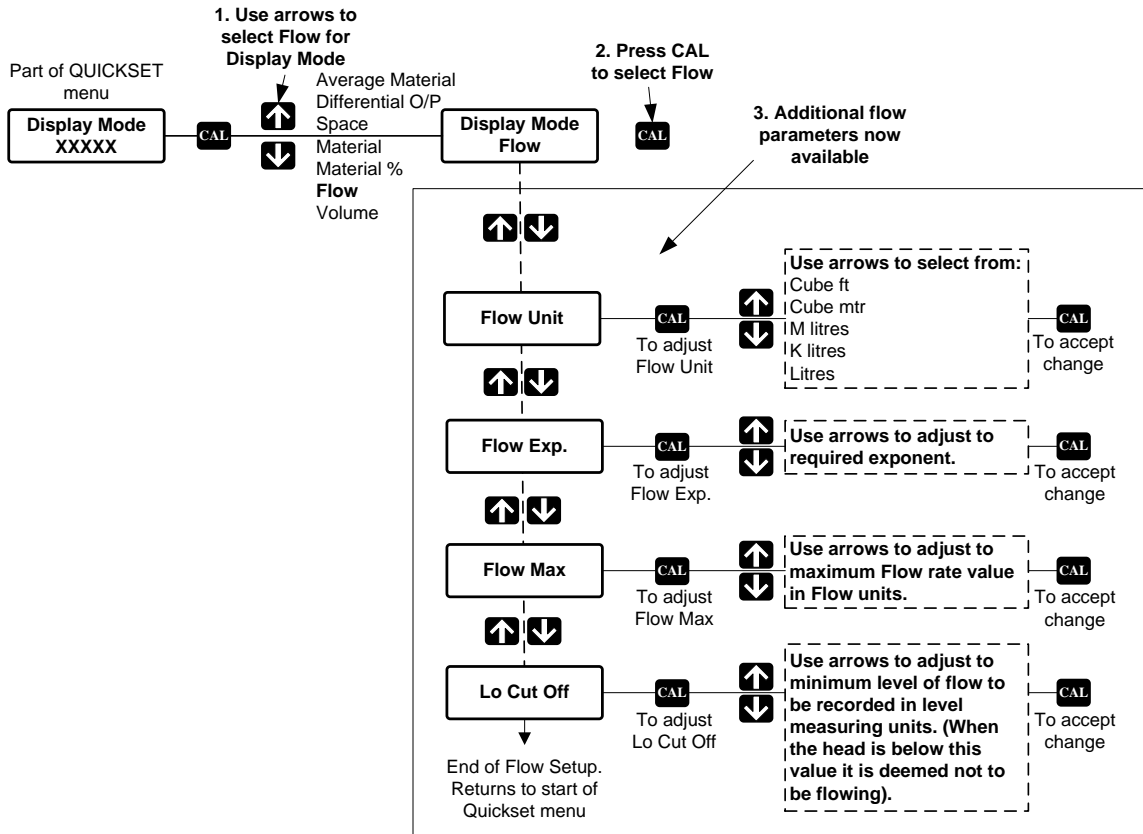

Example

3/2 Rectangular flume, with a maximum flow of 150 l/s at head 0.3m, with a bottom of flume level of 1.30m. Low cut off of 0.010m.

1. Select the required Flow Unit - **Litres**
2. For a 3/2 Rectangular flume enter a Flow Exp. (n) of **1.50**.
3. Enter the maximum flow value **150** l/s that corresponds to the maximum head of 0.3m in Flow Max (Low level – High level).
4. Enter Lo Cut Off of **0.010m**.
5. Ensure that the Low Level value in Quickstart menu is 1.30m from transducer face.
6. Ensure that the High Level Value in Quickstart menu is 1.00m from transducer face.

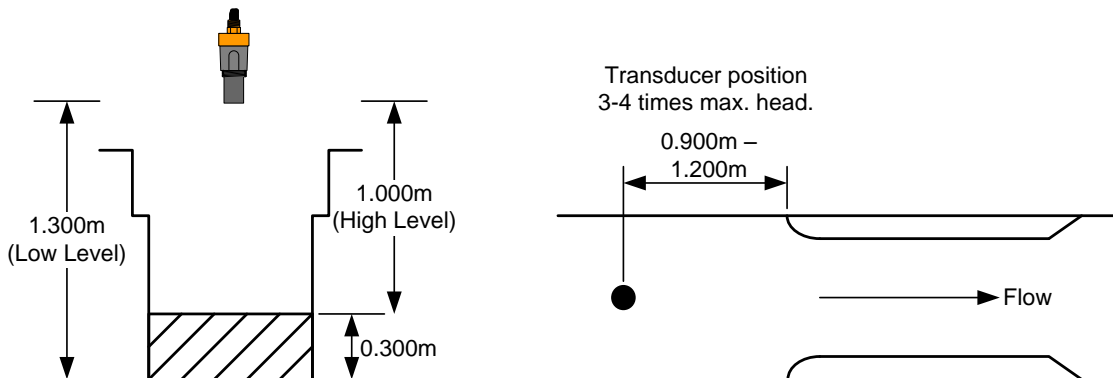

3.3.2 Volume

Volume can only be programmed via the Hycontrol Vision System II programming software package - please refer to Hycontrol office for further information.

3.4 Set-up – Output Adjustments

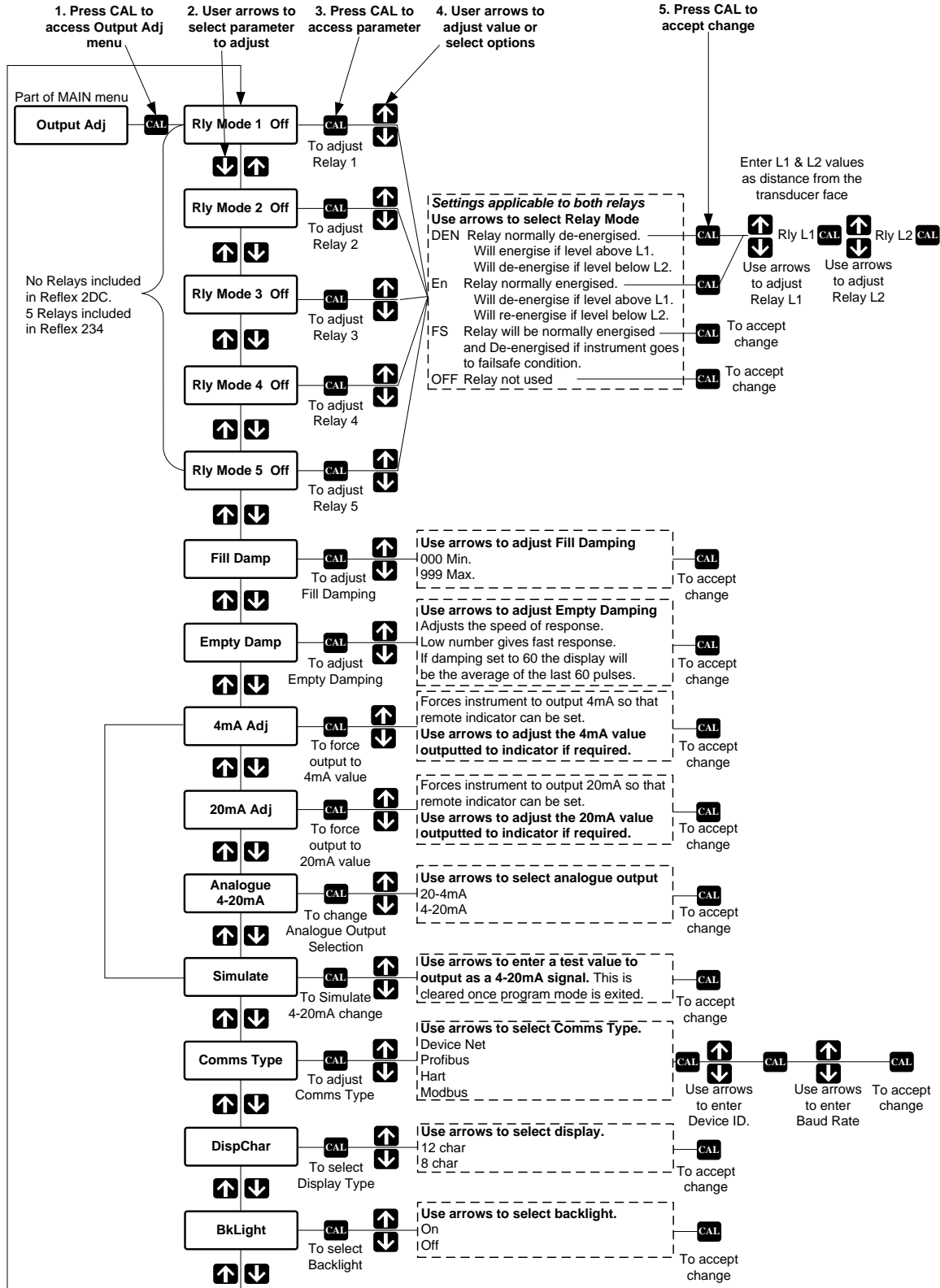

3.5 Tx Set-up for Gain and Threshold

It is only necessary to change the Tx Set-up for Gain and Threshold in difficult applications, usually associated with level control of solids.

- 3.5.1 If, after completing the entry of all Quick Start (Section 3.3) and Output Adjustments (Section 3.4), the instrument is monitoring the level correctly then do not adjust the Tx Set-up parameters.

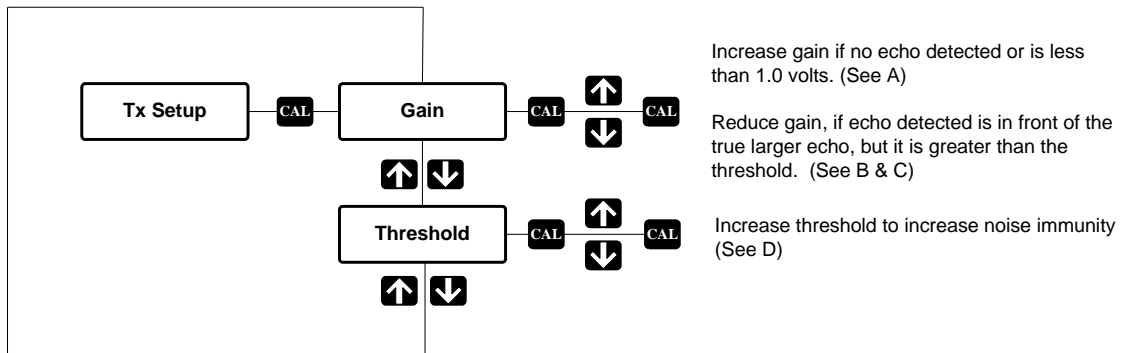

Do go into Diagnostic Display (Section 3.6) and check that the echo size “S” in volts is stable at approximately 1.0 to 2.0 volts.

- 3.5.2 If the instrument is not reading the correct level or the echo size “S” is unstable then go into Tx Set-up (See 3.2) Gain “GN” and adjust “Gain” as follows:



- A. If no echo is detected or the echo size “S” is below 1.0 volt, then increase “Gain” until the echo is detected and “S” equals 1.0 volt minimum.
- B. If the instrument is detecting an echo which is closer to the transducer than the true level, then reduce gain until the correct level is detected. Now check that the echo size “S” is still at least 1.0 volt. If it is below this level contact Hycontrol – it may be that the transducer position is not optimal.
- C. If the echo size “S” is unstable, flicking between two echoes, then increase gain until the echo stabilizes on an incorrect close echo. Note the “Gain” and then reduce the value by 30. This will give the best gain “GN” to use to avoid any close in echoes. Check to ensure that echo size “S” is between 1.0 and 2.0 volts.
- D. Threshold is rarely adjusted unless there is a problem during filling. On occasions the echo, caused by the fill-stream, may be large enough and constant enough for it to be above the threshold setting. This would show itself as a closer unwanted echo. If this occurs, check the size of the unwanted echo “S” in diagnostics and adjust the “Threshold” voltage above the echo size seen during filling.

3.6 Diagnostic Display

If you press the  or  push buttons when the instrument is in its normal RUN mode, the following diagnostics are available.

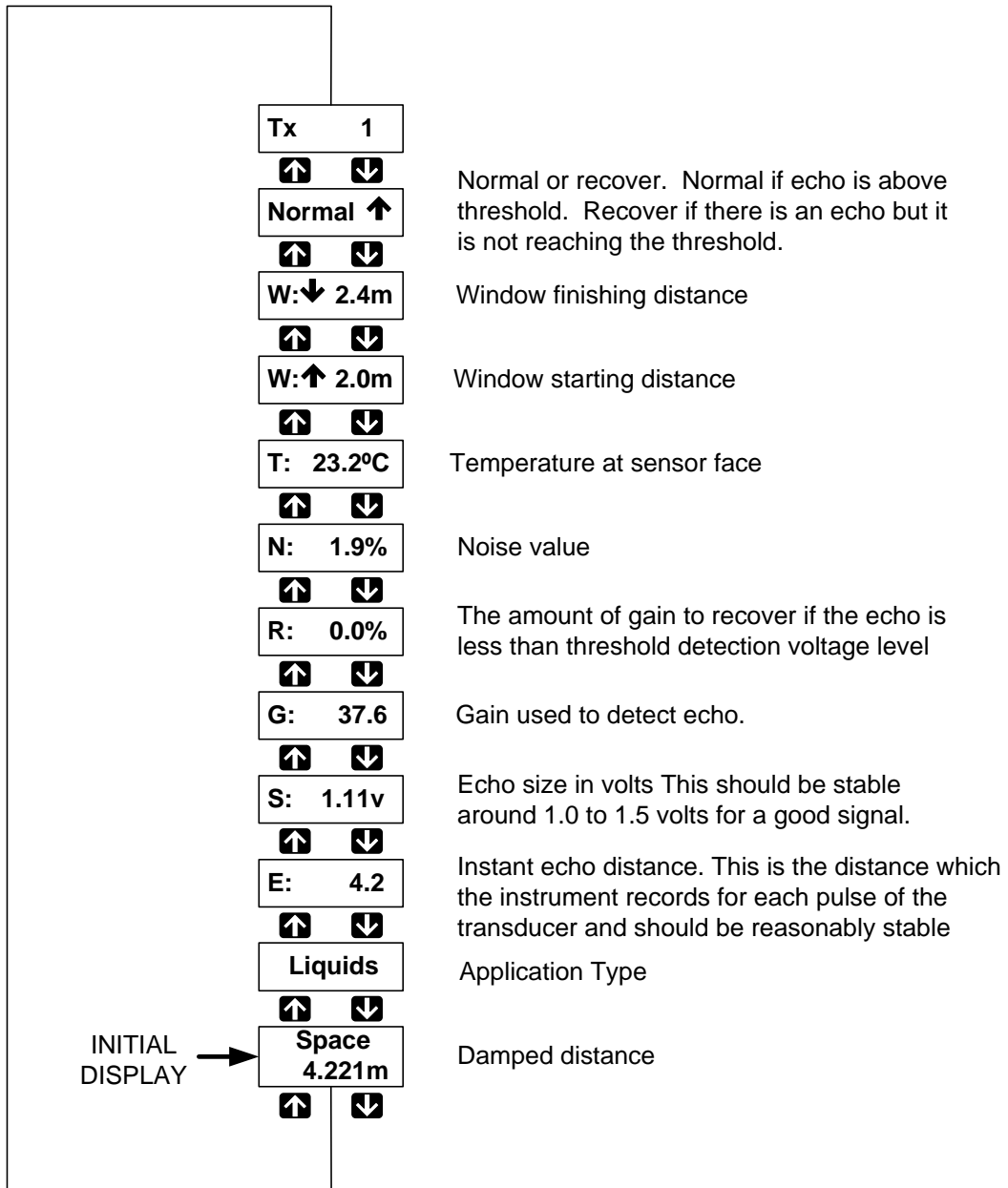

4. GENERAL SPECIFICATION

CONTROLLER	: Reflex LR
	: Reflex LR 2DC - 24V loop powered
	: Reflex LR 234 - 2,3,4 wired AC/DC
Range	: Up to 60 metres
Blanking	: Variable from 0.3 metres (dependent on transmitter)
Process media	: Liquids or Solids
Analogue Output	: 4-20mA into 750 Ohm External Supply. 400 Ohms Internal Supply.
Power Supply	: 12 - 30V DC
	: 90 - 260V AC 50/60Hz
Relays	: 5 Form C SPDT rated 0.5 amp at 240V AC
Resolution	: 1mm up to 20 metre range
	: 4mm from 20-60 metre range
Accuracy	: +/- 0.25% of measured range
Operating temperature	: -40°C to + 80°C *
Display	: 2 line 12 digit LCD
Enclosure	: IP65 (Nema 4x)
Dimensions	: 160h x 165l x 106d
Key Pad	: Integral 4 button
Weight	: 1Kg
Cable Entries	: 3 x 20mm 1 x 16mm Knockouts only, located on enclosure
Comms	: Modbus / HART (Options)
	: Multi-drop capability, up to 32 units
	: Vision System II Software Package
	: Hycontrol GSM Link (GSM/CDMA connectable)
TRANSDUCERS	RVT Series
Operating Temperature	: Refer to transducer part number definition on Page 20.
Transducer IP Rating	: Sealed IP68
Cable length	: 6 metres
Mounting	: RVT10 2" NPT or BSPT RVT20 4" Flanged ANSI, DIN or JIS RVT40/60 10" Flanged ANSI, DIN or JIS
Weight	: RVT10 1.5Kg (Typical weight) RVT20 3.5Kg (Typical weight including flange & cone) RVT40 9.5Kg (Typical weight including flange & cone) RVT60 13.5Kg (Typical weight including flange & cone)

*For ATEX models refer to ATEX Safety & Operating Instructions manual.

5. REFLEX LR INTEGRAL PART NUMBERS Controller

MODEL	Reflex LR Ultrasonic Level Controller							
REFLEX LR								
	Type							
	2DC	2 Wire Loop Powered Transceiver						
	234	2, 3 & 4 Wire Transceiver						
	Housing							
	W	Wall Mount						
	P	Panel Mount						
	Power Supply							
	B	24V DC standard						
	U	Universal power supply 90-260 VAC (on 234 only)						
	Output Module							
	A	4-20mA analogue output module						
	X	Not Reqd						
	M	Modbus with 4-20mA output module (on 234 only)						
	H	4-20 mA module output with HART (on 2DC only)						
	W	Modbus without 4-20mA output module (on 234 only)						
	P	Profibus DP (on 234 only)						
	Z	Special						
	Internal Hycontrol Link Modem							
	XX	Not required						
	G4	GSM Freq 900/1900 Mhz for Europe and Aust						
	Approvals							
	X	Without						
	A	ATEX EEx ia * (2DC wall only)						
	D	ATEX DIP *						
	REFLEX LR	234	W	U	M	XX	A	Typical Part Number

*For ATEX models refer to ATEX Safety & Operating Instructions Manual.

Transducers

MODEL	Reflex LR Ultrasonic Level Transducers									
RVT10	30kHz 10m max									
RVT20	20kHz 20m max									
RVT40	10kHz 40m max									
RVT60	5kHz 60m max									
Process Temperature - Transducer Facing Material *										
S	Standard Temperature ~ Dry product ~ Polyolefin face, 10 & 5KHz (-40°C to 80°C)									
T	Standard temperature ~ Wet atmosphere ~ Teflon face, 30 & 20KHz (-40°C to 80°C)									
Y	High Temperature ~ Wet and Dry atmosphere ~ Titanium Face, 10KHz only (-40°C to 150°C)									
Z	Special									
Transducer Housing Material										
4	Polypropylene - Standard		20, 10 & 5KHz							
6	Teflon		30KHz only							
Process Connection / Thread Size / Dimensions Standard										
FA	ANSI Flange									
FD	DIN Flange									
FJ	JSI Flange									
SB	BSP		30KHz only							
SN	NPT		30KHz only							
XX	Not Required									
Process Connection Size / Flange Size										
02	2" Thread		30KHz only							
04	4" Flange only		Standard on 20KHz							
10	10" Flange only		Standard on 10 & 5KHz							
XX	Not required									
Flange Material										
4	Polypropylene									
X	Not required									
Z	Special									
Cone Size										
xx	Not required									
04	4"									
10	10"									
Z	Special Request									
Cone Material										
X	Not Applicable									
4	Polypropylene									
8	Polyurethane									
Z	Special									
Approvals										
X	Without									
A	ATEX EExia *									
M	ATEX EExm *									
D	ATEX DIP *									
Connection										
C	Integral 6 metre cable									
Sxx	Custom specification									
RVT10	S	4	SB	02	X	XX	X	X	C	Typical Part Number

*For ATEX models refer to ATEX Safety & Operating Instructions Manual.

6. LABELLING INFORMATION.

Standard label fitted to all Reflex LR controllers and RVT transducers.



7. MODBUS REGISTER LIST

BASIC MODBUS SPAN AND DIAGNOSTIC REGISTERS FOR HYCONTROL REFLEX LR SERIES INSTRUMENTS

Hycontrol Reflex LR series units communicate using '2 wire' (plus Ground) RS485 connection, and can be connected in 'multi-drop' configurations.

Protocol: Modbus RTU (2 wire)
Speed: 19200 Baud
Data bits: 8
Parity: None
Stop Bits: 1

Hycontrol Reflex LR series units act as 'slave' devices on a Modbus network.

Units are shipped from the factory with a default Modbus address of 01. The Modbus address of any unit can be changed individually if units are to be connected in a multi-drop network. Each address number must only be used once on any network (possible addresses are 1...255).

Diagnostic Block (*Read Only*): *Can be read as Singles or any Block wholly within the limits of this range of addresses*

40124 -	LOW LEVEL span set point in mm
40125 -	HIGH LEVEL span set point in mm
40126 -	DISPLAYED DISTANCE (DISTANCE) in mm
40127 -	NOT USED
40128 -	NEW DISTANCE (E-DISTANCE) in mm
40129 -	CONFIRM DISTANCE (C-DISTANCE) in mm
40130 -	ECHO SIZE in Volts/102
40131 -	GAIN at Echo detection point in %/7.5
40132 -	NOT USED (Gain Limit)
40133 -	RECOVER GAIN currently being used in %/7.5
40134 -	NOISE in %/7.5
40135 -	TEMPERATURE in Degrees K/10 ((DegreesC+273.2)/10)
40136 -	NOT USED
40137 -	CONFIRM COUNTER current value
40138 -	HOLD COUNTER current value
40139 -	NOT USED
40140 -	WINDOW FORWARD POSITION in mm
40141 -	WINDOW BACK POSITION in mm

Identity Information (Read Only): *MUST Read as SINGLES-NOT BLOCKS*:

- 40002 - SERIAL NUMBER raw number
- 40003- TYPE NUMBER raw binary values- bits defined as listed here:
 - Bit0- Power Configuration- '0'= 234 wire
'1'= 2 wire
 - Bit1- Range/Resolution- '0'=Standard(60m/1mm)
'1'=Long(175/4mm)
 - Bit5- Mechanical Config- '0'=Remote
'1'=Integral
- 40004- AMPLIFIER SOFTWARE VERSION raw number/100
- 40005- AMPLIFIER MODBUS ID raw number
- 40006- AMPLIFIER MODEL NUMBER- values defined as listed here:
 - 0-Ultrasonic Air
 - 1-Sonar
 - 7-N/A
 - 8-N/A
 - 9-N/A
- 40402- TRANSDUCER SERIAL NUMBER raw number
- 40403- TRANSDUCER MODEL NUMBER raw number (tx freq. in kHz)
- 40404- TRANSDUCER SOFTWARE VERSION raw number/100
- 40405- TRANSDUCER MODBUS ID raw number

Span Adjustment (Read/Write) *MUST Read/Write SINGLES-NOT BLOCKS*:

- 40013 - LOW LEVEL span set point in mm
- 40014 - HIGH LEVEL span set point in mm

RELAY Function Adjustment (Read/Write) *MUST Read/Write SINGLES-NOT BLOCKS*:

- 40052- Relay 1 Mode setting- values defined as listed here:
 - 0-OFF
 - 1-FS (Failsafe)
 - 2-EN (Energise on Level)
 - 3-DEN (De-Energise on Level)
- 40053- Relay 2 Mode setting- values defined as listed for Relay 1 above
- 40054- Relay 3 Mode setting- values defined as listed for Relay 1 above
- 40055- Relay 4 Mode setting- values defined as listed for Relay 1 above
- 40056- Relay 5 Mode setting- values defined as listed for Relay 1 above
- 40036- Relay 1 L1 set point in mm
- 40037- Relay 1 L2 set point in mm
- 40038- Relay 2 L1 set point in mm
- 40039- Relay 2 L2 set point in mm
- 40040- Relay 3 L1 set point in mm
- 40041- Relay 3 L2 set point in mm
- 40042- Relay 4 L1 set point in mm
- 40043- Relay 4 L2 set point in mm
- 40044- Relay 5 L1 set point in mm
- 40045- Relay 5 L2 set point in mm

Extended Params (Read/Write) *MUST Read/Write SINGLES-NOT BLOCKS*:

- 40060- DISPLAY UNITS parameter setting- values defined as listed here:
 - 0-Frequency (Hz) *Not valid for level instruments*
 - 1-Pressure (kPa) *Not valid for level instruments*
 - 2-Pressure (PSI) *Not valid for level instruments*
 - 3-Millimetres
 - 4-Centimetres
 - 5-Metres
 - 6-Feet
 - 7-Inches
- 40015- FAILSAFE MODE parameter setting- values defined as listed here:
 - 0- 3.5mA
 - 1- 3.8mA
 - 2- 20.2mA
 - 3- Last Known
 - 4- 4.0mA
 - 5- 20.0mA
- 40016- FAILSAFE TIME parameter setting- in seconds
- 40017- APPLICATION TYPE parameter setting- values defined as listed here:
 - 0-Liquid
 - 1-Solid
 - 2-Slurry
 - 3-Position
- 40018- FILL RATE parameter setting- in metres per hour/10
- 40019- EMPTY RATE parameter setting- in metres per hour/10
- 40020- DISPLAY MODE parameter setting- values defined as listed here:
 - 1-Volume
 - 2-Flow
 - 3-Material %
 - 4-Material
 - 5-Space
 - 6-Differential Output
 - 7-Average Material
- 40065- FLOW UNITS parameter setting- values defined as listed here:
 - 32-Litres
 - 33-Kilolitres
 - 34-Megalitres
 - 35-Cubic Metres
 - 36-Cubic Feet
- 40031- FLOW EXPONENT parameter setting- in raw units/100
- 40032- FLOW MAX parameter setting- in selected flow units per second/10
- 40033- LOW CUT OFF parameter setting- in mm
- 40033- OFFSET parameter setting- in mm (0-5000)
- 40021- LOCK CODE parameter setting- raw number
- 40022- FILL DAMPING parameter setting- raw number
- 40023- EMPTY DAMPING parameter setting- raw number

- 40064- ANALOG mode parameter setting- values defined as listed here:
 0- 4-20mA (4mA low, 20mA high- standard)
 1- 20-4mA (20mA low, 4mA high- inverted)
- 40448- GAIN parameter setting in %/7.5
 40449- GAIN STEP parameter setting in %/7.5
 40450- DISTANCE STEP parameter setting in mm
 40451- THRESHOLD parameter setting in Volts/100
 40452- BLANKING parameter setting in mm
 40453- EMPTY DISTANCE parameter setting in mm
 40454- TEMPERATURE ADJ parameter setting- raw number
 40455- DISTANCE ADJ parameter setting in mm
 40456- VELOCITY parameter setting Value/10000
 40457- MAP DISTANCE parameter setting in mm
 40458- MAP USED parameter setting in mm
 40461- MAP MARGIN parameter setting in %/7.5
 40434- RECOVER FIRST parameter setting in %/7.5
 40435- RECOVER MAX parameter setting in %/7.5
 40436- RECOVER INCREMENT parameter setting in %/7.5
 40437- WINDOW parameter setting in mm
 40438- WINFWD INC parameter setting in mm
 40439- WINBACK INC parameter setting in mm
 40440- CONFIRM parameter setting- raw number
 40441- HOLD parameter setting- raw number
 40442- TX VOLTAGE parameter setting in V/413.25
 40445- NOISE SWITCH parameter setting in %/7.5
 40446- ECHO WIDTH parameter setting in mm
 40433- SEARCH FIRST parameter in %/7.5
 40034- MOVEMENT parameter setting in mm
 40419- SLOPE DIST parameter setting in mm
 40420- SLOPE INC parameter setting in %/7.5
 40421- DETECTOR parameter setting in V/1240.7
 40422- GAIN STEP1 parameter setting in %/7.5
 40423- DISTANCE STEP1 parameter setting in mm
 40424- GAIN STEP2 parameter setting in %/7.5
 40425- DISTANCE STEP2 parameter setting in mm
 40426- GAIN MAX parameter setting in %/7.5
 40427- PULSE POWER parameter setting- raw number
 40428- PULSE RATE parameter setting- raw number
 40429- FREQUENCY parameter setting- raw number
 40430- FILTER parameter setting- raw number
 40431- ADVANCED FILTER parameter setting- raw number
 40026- I-WASTE parameter setting in mA/1000
 40035- I-CHARGE parameter setting in mA/37.22

8. ASSEMBLY OF FLANGE AND CONES.

05, 10 & 20KHz – Transducer Assembly Process

1. Remove red cap (including cardboard).



2. Screw the flange assembly fully down onto the cone (as far down as it will go until the parts are tightly fastened).



3. Screw the transducer tightly down onto the flange and cone assembly.

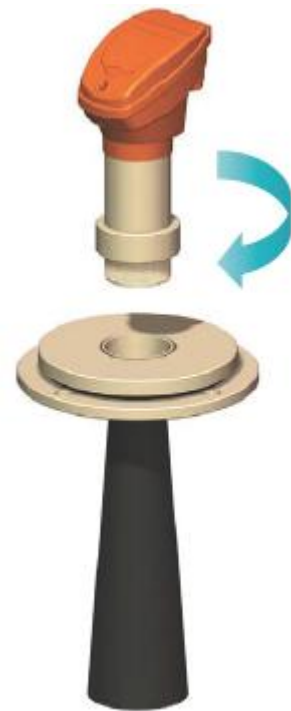

4. Tighten the locking ring down to the flange to fix the components in place.



COMPLETED
ASSEMBLY

APPENDIX A. CROSS TALK PREVENTION

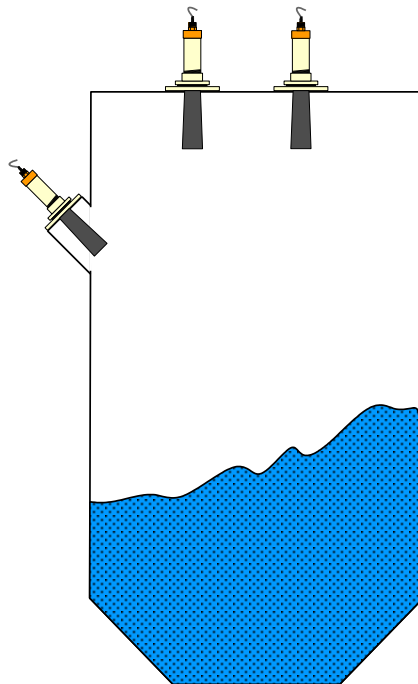

Setup

1. Units to be linked must have a common ground connection, or wire between '⊕', or 'DC -' terminals (parallel connection of all units).

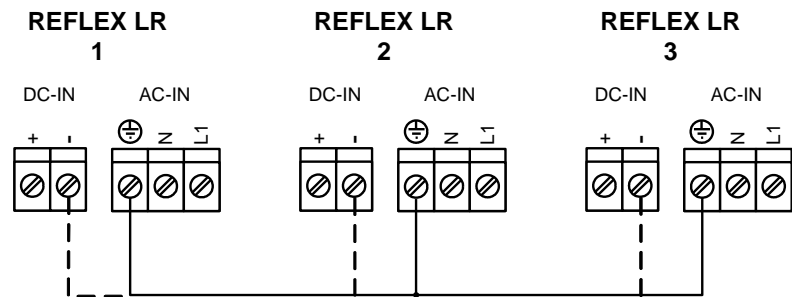

NOTE:- '⊕' and 'DC IN-' are electrically the same

- At each unit, wire a connection between Relay 1 'COM' terminal and the terminal labeled 'TEST'.
- Wire a connection between the Relay 1 'NO' terminal on each unit linked together (parallel connection of all units).

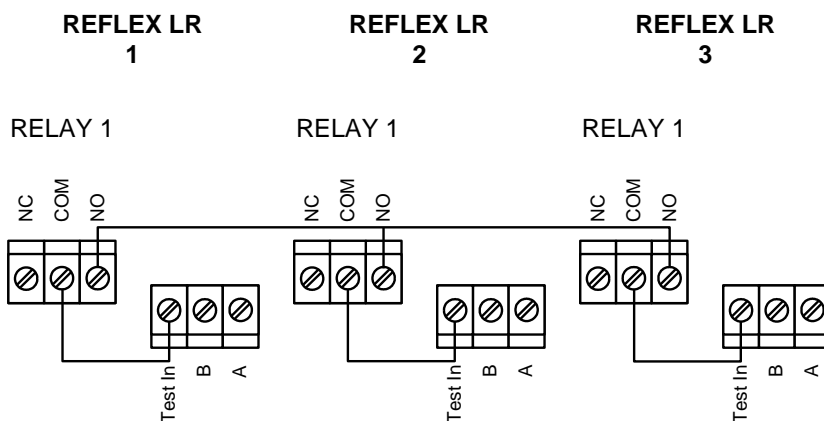

- In the software setup of each unit, program 'RlyMod1' (Relay Mode 1) parameter to 'FS' (Failsafe) mode in Output Adjust menu. (You could use a different relay number in the same way if relay 1 is needed for another function).

The units will now be linked so that they cannot crosstalk.

Theory

The 'TEST' terminal acts as an input when the unit is about to pulse, and will cause the instrument to enter a paused state (not pulse) if you apply a connection to ground. Each unit also drives its own 'TEST' terminal to ground when it is busy pulsing. These two functions combined mean that if two or more units have their 'TEST' terminals connected in parallel, and share a common ground, then at any time when one is pulsing, it will ground the 'TEST' terminals of all units it is connected to, and temporarily pause them until it is finished, then release them. The next unit, which is ready to pulse, then does the same thing in turn, and the process repeats.

The connections above also include the normally open contact of a relay programmed into Failsafe mode in line with the 'TEST' terminals. The function of this is simply to prevent a possible lock up of the whole system if one unit has a problem (such as power failure). Any time that a unit is in the failed state, it will be disconnected by the relay from the other units, so they can continue working together.

APPENDIX B. DIFFERENTIAL LEVEL MEASUREMENT

In this mode, the controller drives two transducers to measure the difference in levels by subtracting the downstream level from the upstream level. Negative results will be set to zero. Please see connection diagram on page 32 for transducer wiring.

The upstream transducer should be chosen to give a positive differential value.

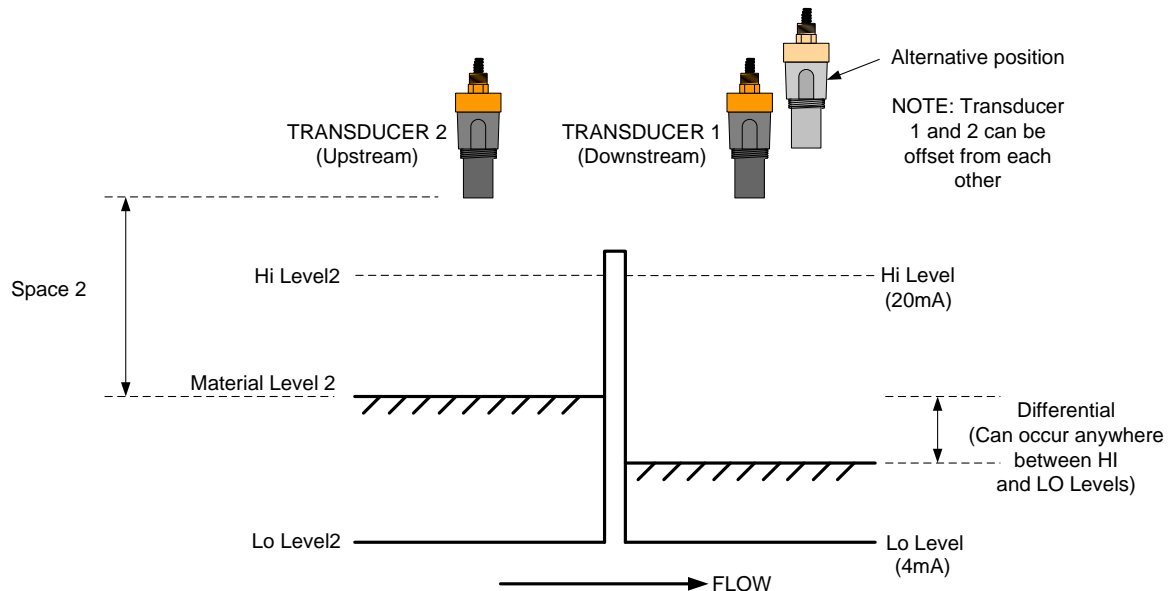

Sensor Addressing

All transducers are originally supplied with a MODBUS address of 1. When using two transducers for differential measurement the upstream transducer is to be reprogrammed to have a different MODBUS address typically 2.

To program transducers follow these steps

1. With no transducers connected power up controller. (Shows error 1 on display)
2. Set the **Disp Mode** in Quickset menu (Section 3.3 Page 13) to **Diff O/P** on controller. (This enables 4 additional parameters as shown in flow diagram on Page 30).
3. Connect the upstream transducer.
4. In Quickset menu set **2:SenAdd** to **1** and press **Cal** button twice.
5. Set the **2:TxAdd** to **2**. (NOTE:- This has changed the MODBUS address of the transducer originally programmed as 1 to 2. It is useful, to prevent confusing the transducers, to mark this new address on the transducer itself. Also to revert this transducer for use on a non differential application would require 2:TxAdd to be changed back to 1 using steps 1 -7 again)
6. Connect downstream transducer as well (already set with address of 1).
7. In Quickset menu set **2:SenAdd** to **2**.

The controller is now set for differential operation and should pulse the 2 transducers alternately.

Parameters 1:SenAdd and 2:SenAdd: in Quickset menu hold the MODBUS addresses of the transducers to be connected. The default addresses in 1:SenAdd = 1 and in 2:SenAdd = 2.

Important notes:

- Changing *SenAdd*, does not change the transducer modbus address, only the transducer address the controller communicates with.
- To change the transducer modbus address, change the *TxAdd*.
- To get to *TxAdd* parameter press CAL twice when on *SenAdd*.

Transducer parameter setup

Each transducer has its own Hi and Lo levels. Parameters Lo Level and Hi Level are for transducer 1; LoLevel2 and HiLevel2 are for transducer 2. These are useful when the sensors are not mounted at the same levels, but assumes that Lo Levels are physically the same level.

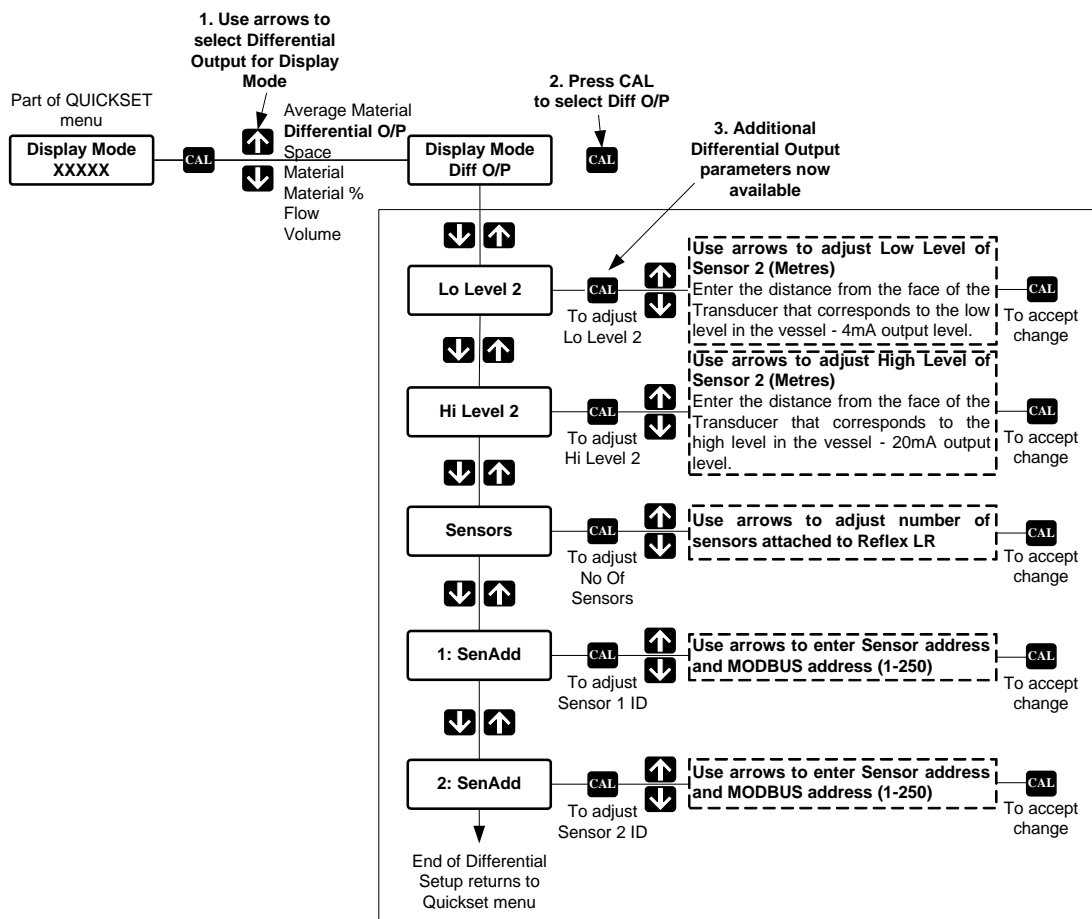

Differential Calculation (refer to diagram Pg. 29)

The differential value is calculated by subtracting the material level measured by transducer 1 (Downstream) from the material level measured by transducer 2 (Upstream) as shown below. A negative value is set to zero.

$Diff = MaterialLevel2 - MaterialLevel1$ (Actual measured differential)

$MaterialLevel2 = LowLevel2 - Space2$ (Distances from transducer face)

$MaterialLevel1 = Lowlevel1 - Space1$ (Distances from transducer face)

Analog output is calculated based on the differential value.

The max span of the analog output is set between the Lo Level and Hi Level. The analog output is calculated according to the following equation:

$Current (mA) = 16 \times (Diff) / (Lo Level1 - Hi Level1) + 4mA$

Relays (Only in Reflex 234)

The relays are switched based on the diff value. For up to 5 relays, the Relay Set Points L1 and L2 (in Output adjust menu Pg. 15) should be set to diff values that the relay is required to switch at.

Relay Mode = EN (L1 < L2)
Energise on decreasing Diff

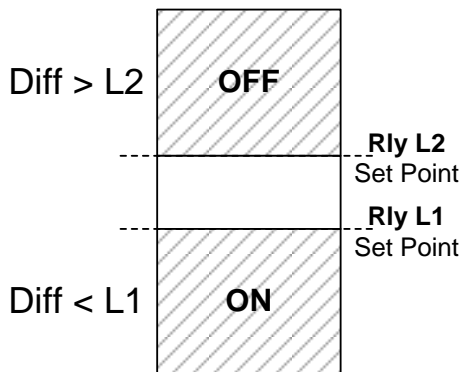

Relay Mode = DEN (L1 < L2)
Energise on increasing Diff

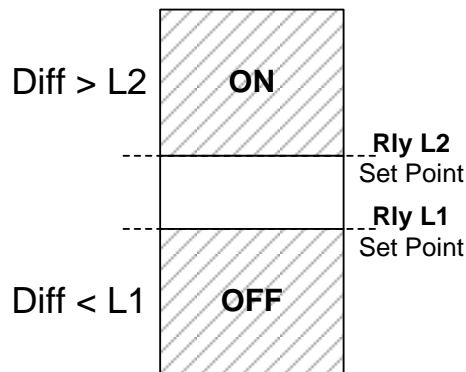

Accessing both Transducers' Parameters

Both transducer 1 and transducer 2 parameters can be accessed through KeyPad and Vision System II.

Via KeyPad

Parameter in TxSetup, Tracking and Factory menus determine the transducer that is accessed currently through that menu. Select transducer value 1 or 2 in any of the above menus to access that transducer's parameters.

Via Vision System II

When in Run mode, press down key once to get Tx value on display. If Tx is 1, then Vision System II is communicating with transducer 1 (downstream). To swap to the other transducer hold both Up and Down keys simultaneously.

Differential level transducer wiring diagram

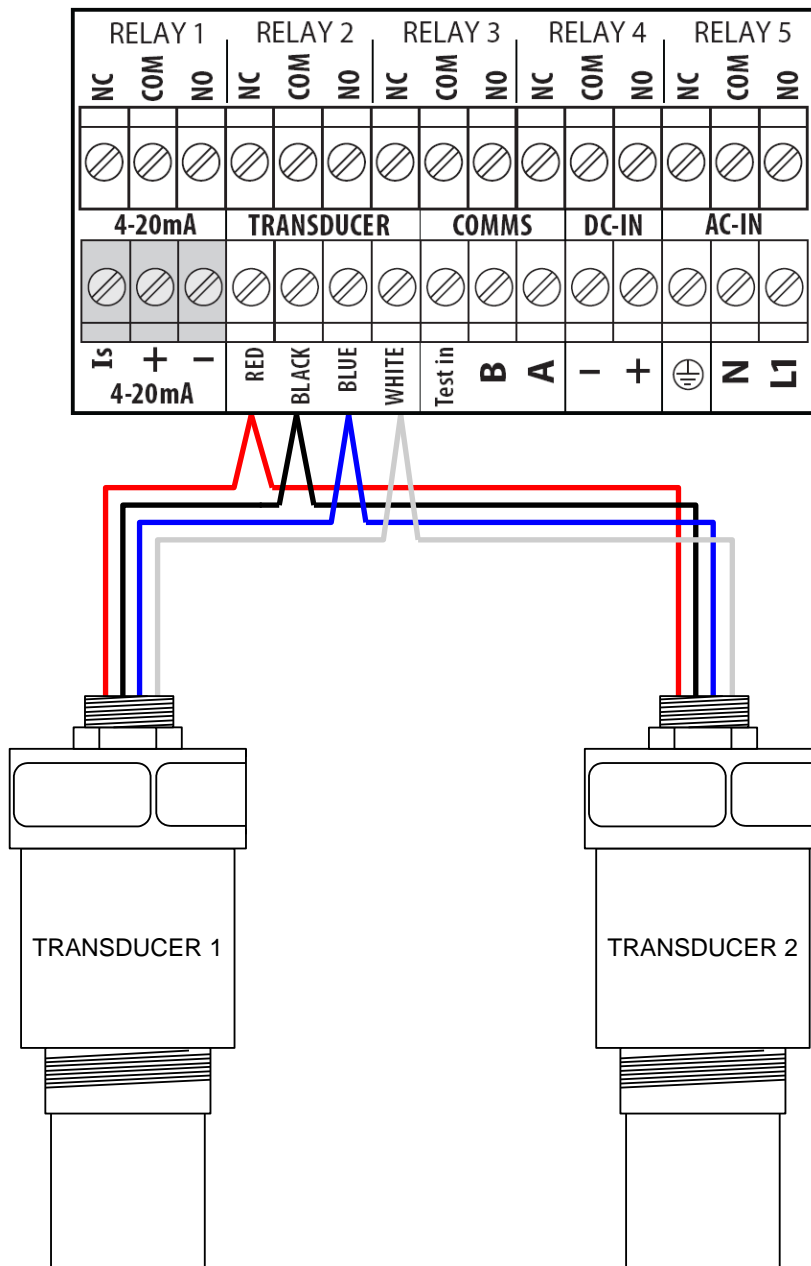

Appendix C. APPLICATION TYPES

Hycontrol have added additional application types to the software from v5.78 (released December 2012) along with a basic selection of process speed of 'Fast', Medium, or 'Slow'. You can also manually select and adjust the fill & empty speeds (in selected unit per hour e.g. metres per hour) by using the 'Custom' option.

The application types are selectable in the 'QuickSet' menu, after selecting the application type you will see the menu item 'Fill Speed View'. Pressing 'Cal' will allow you to use the arrows to scroll through the options 'Custom', 'View', 'Fast', 'Medium' or 'Slow'. Pressing 'Cal' whilst displaying 'View' will show the currently selected speed in units per hour.

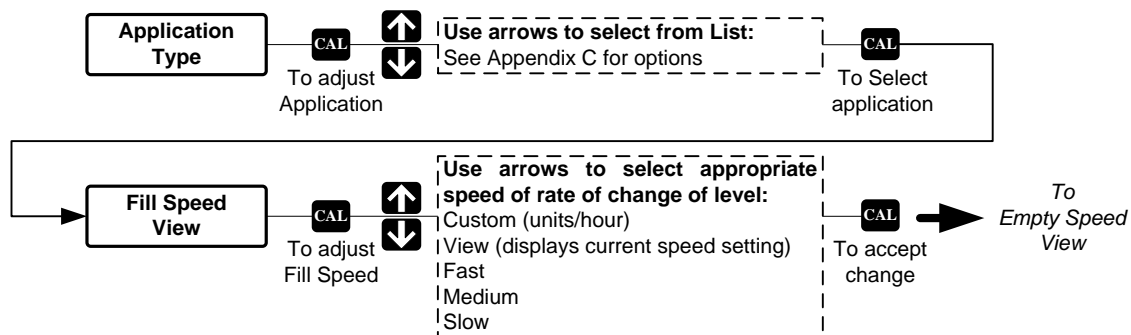

Bin Level

Fast Fill 100m/h Empty 100m/h
Med Fill 50m/h Empty 50m/h
Slow Fill 10m/h Empty 10m/h

Cement

Fast Fill 20m/h Empty 20m/h
Med Fill 10m/h Empty 10m/h
Slow Fill 5m/h Empty 5m/h

Coal

Fast Fill 100m/h Empty 100m/h
Med Fill 50m/h Empty 50m/h
Slow Fill 10m/h Empty 10m/h

Conveyor

Fast Fill 6000m/h Empty 6000m/h
Med Fill 3000m/h Empty 3000m/h
Slow Fill 1000m/h Empty 1000m/h

Crusher

Fast Fill 800m/h Empty 800m/h
Med Fill 200m/h Empty 200m/h
Slow Fill 20m/h Empty 20m/h

Detection

Fast Fill 6000m/h Empty 6000m/h
Med Fill 3000m/h Empty 3000m/h
Slow Fill 1000m/h Empty 1000m/h

Iron Ore

Fast Fill 100m/h Empty 100m/h
Med Fill 50m/h Empty 50m/h
Slow Fill 5m/h Empty 5m/h

Liquids

Fast Fill 200m/h Empty 200m/h
Med Fill 50m/h Empty 50m/h
Slow Fill 5m/h Empty 5m/h

Agitated Liquids

Fast Fill 200m/h Empty 200m/h
Med Fill 60m/h Empty 60m/h
Slow Fill 10m/h Empty 10m/h

Agitated Liquids

Fast Fill 200m/h Empty 200m/h
Med Fill 50m/h Empty 50m/h
Slow Fill 10m/h Empty 10m/h

Ore

Fast Fill 100m/h Empty 100m/h
Med Fill 50m/h Empty 50m/h
Slow Fill 5m/h Empty 5m/h

Plastics

Fast Fill 20m/h Empty 20m/h
Med Fill 10m/h Empty 10m/h
Slow Fill 5m/h Empty 5m/h

Positioning

Fast Fill 4000m/h Empty 4000m/h
Med Fill 2000m/h Empty 2000m/h
Slow Fill 1000m/h Empty 1000m/h

Powder

Fast Fill 30m/h Empty 30m/h
Med Fill 15m/h Empty 15m/h
Slow Fill 5m/h Empty 5m/h

Reflective

Fast Fill 20m/h Empty 20m/h
Med Fill 10m/h Empty 10m/h
Slow Fill 5m/h Empty 5m/h

ROM Bin

Fast Fill 1200m/h Empty 400m/h
Med Fill 700m/h Empty 250m/h
Slow Fill 300m/h Empty 100m/h

Silo Level

Fast Fill 100m/h Empty 100m/h
Med Fill 50m/h Empty 50m/h
Slow Fill 10m/h Empty 10m/h

Slurry

Fast Fill 100m/h Empty 100m/h
Med Fill 50m/h Empty 50m/h
Slow Fill 20m/h Empty 20m/h

Solids

Fast Fill 100m/h Empty 100m/h
Med Fill 50m/h Empty 50m/h
Slow Fill 10m/h Empty 10m/h

Stockpile

Fast Fill 200m/h Empty 200m/h
Med Fill 50m/h Empty 50m/h
Slow Fill 20m/h Empty 20m/h

Sump

Fast Fill 200m/h Empty 200m/h
Med Fill 40m/h Empty 40m/h
Slow Fill 10m/h Empty 10m/h

Process Sump

Fast Fill 1000m/h Empty 1000m/h
Med Fill 300m/h Empty 300m/h
Slow Fill 20m/h Empty 20m/h

Tank Level

Fast Fill 200m/h Empty 200m/h
Med Fill 50m/h Empty 50m/h
Slow Fill 5m/h Empty 5m/h